



Plug and Play CNC Controller Technical Manual

v2022Q1.3, 21.2 Model Revision

System Overview

Major Components

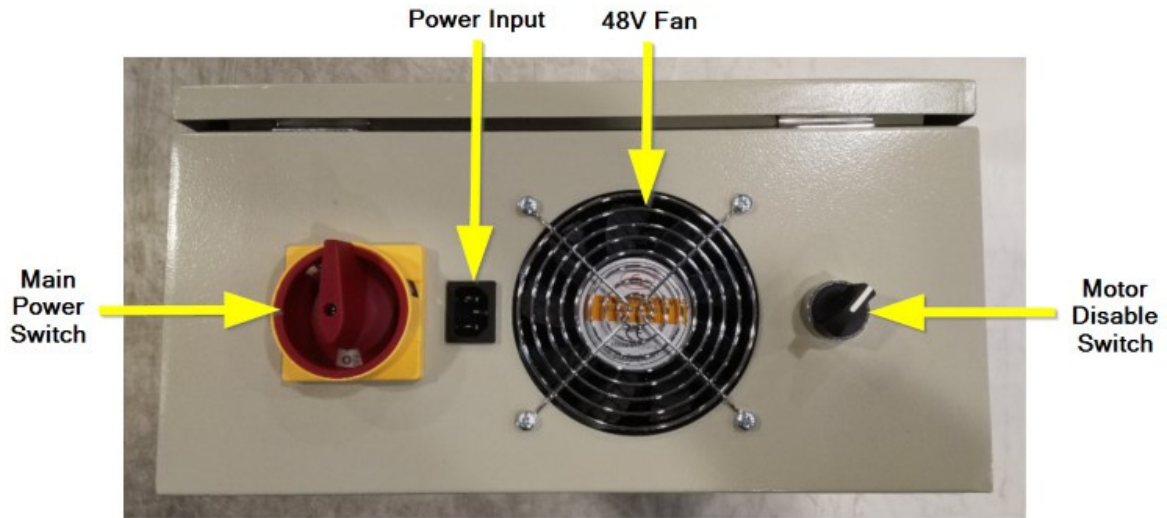

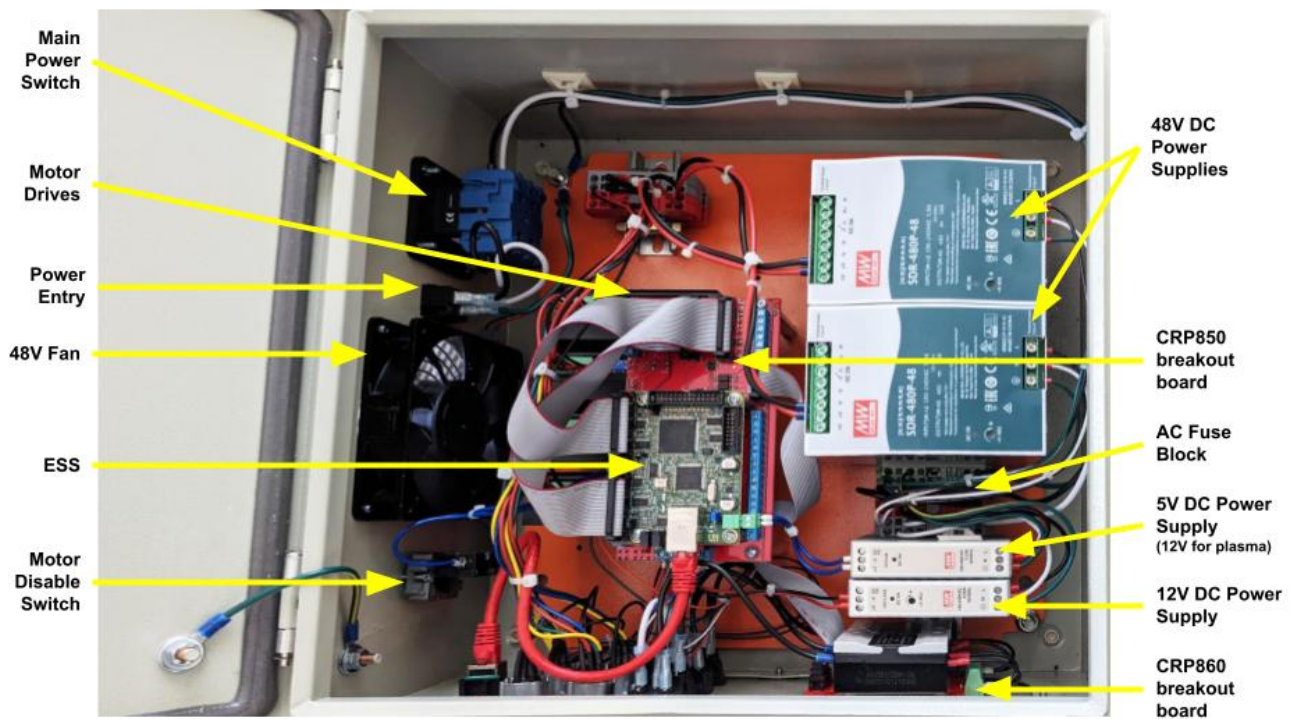

Main Power Switch

Motor Drives

Power Entry

48V Fan

ESS

Motor Disable Switch

48V DC Power Supplies

CRP850 breakout board

AC Fuse Block

5V DC Power Supply (12V for plasma)

12V DC Power Supply

CRP860 breakout board



Emergency Stop



The emergency stop system is a normally closed circuit and must be plugged in for the CNC controller to operate. It is recommended to keep it within easy reach during machine operation so it is quickly accessible if the machine needs to be emergency stopped.

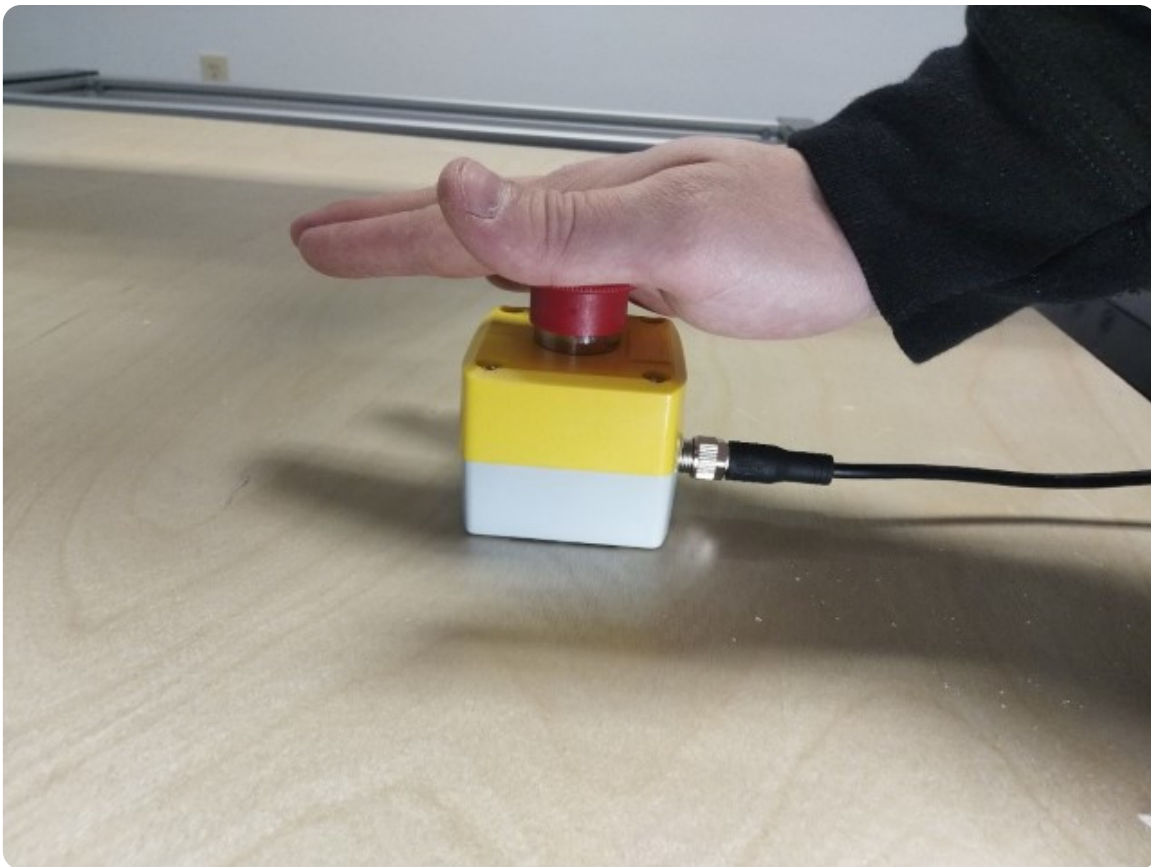

To activate the emergency stop, press down on the red button. The machine will come to an immediate stop and all outputs connected to the CNC controller will be turned off.



In order to clear the emergency stop, twist the red button clockwise until it releases.

Motor Disable Switch



The motor disable switch can be found on the side of the box below the fan. Using the motor disable switch will disconnect power to the motor drives and motors. This works as a safety measure and allows you to perform maintenance, manually move the machine, or disconnect and reconnect motors without any danger to the motors or drives.

System Identification

Plug and Play CNC Controllers produced after November 1, 2021 can be identified using the serial number located on the inside of the CNC controller lid.

CRP800-00E - N23 - D4 - EX - 21.2.1 N-210104-182011-1

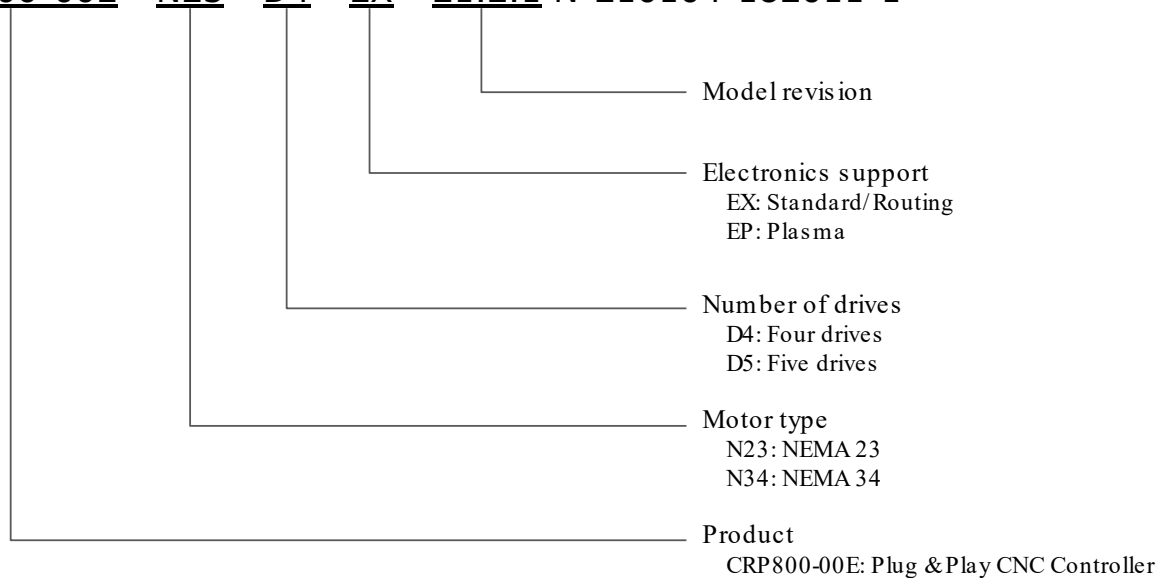

System Requirements

Size Requirements

CRP800-00E Control Box

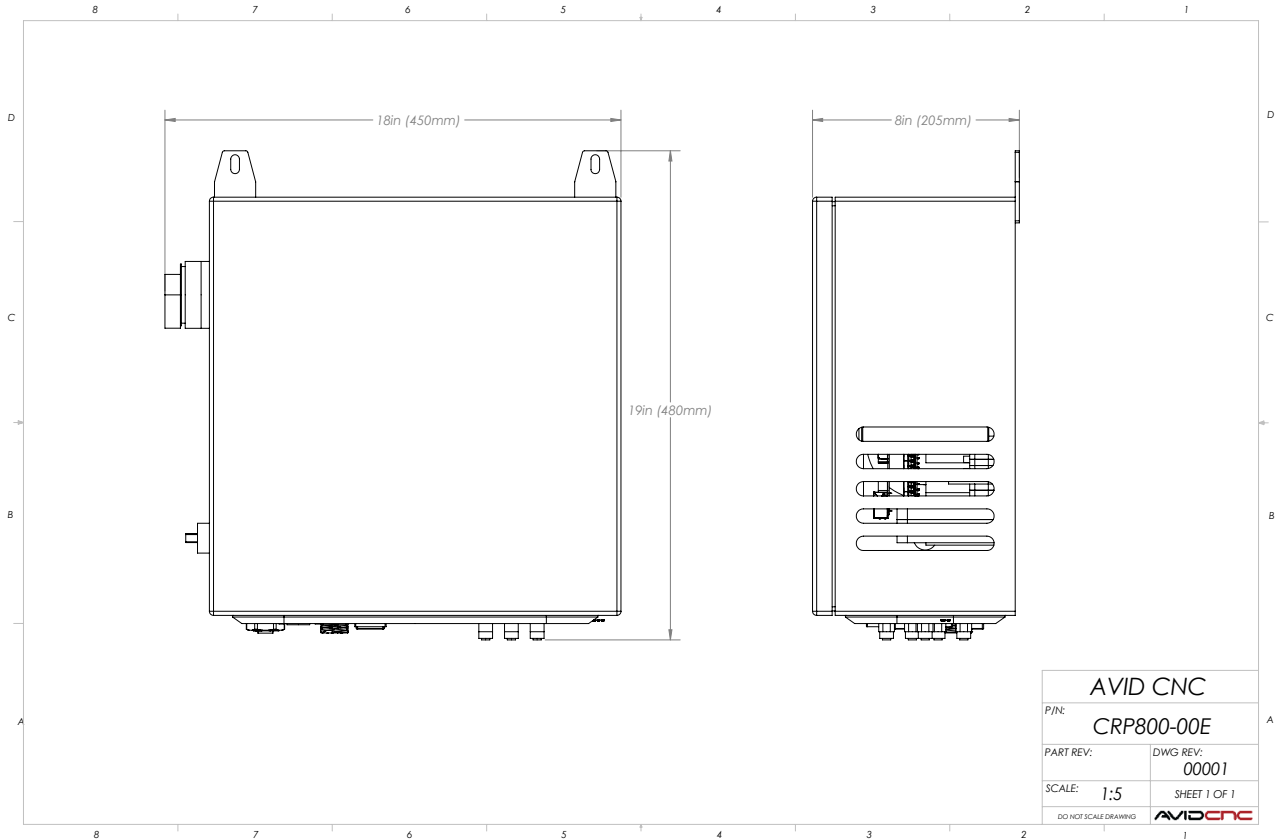

Power Requirements

NEMA 23 CNC Controller:

- Input power: 100-240VAC, 50/60Hz
- Current draw (approx.): 6A @ 120VAC, 3A @ 240VAC

NEMA 34 CNC Controller:

- Input power: 100-240VAC, 50/60Hz
- Current draw (approx.): 12A[†] @ 120VAC, 6A @ 240VAC

[†] The C13 type input power socket is rated for 15A in North America and 10A in most international regions. In those regions the Plug & Play Controller should be powered with 200+ VAC.

Plug and Play Spindle / VFD Systems:

Please see the **Power Requirements** section in our Plug and Play Spindle / VFD Manual.



Initial Setup

Avid CNC Plug and Play Spindle Connections

Refer to the appropriate setup instructions for your Spindle/VFD package:

- Plug and Play Spindle / VFD System: [CRP800 VFD Setup Guide](#)

Avid PRO CNC Plasma System Connections

Refer to the PRO CNC Plasma setup instructions: [PRO CNC Plasma Instructions](#)

Relay 1 Output Connections

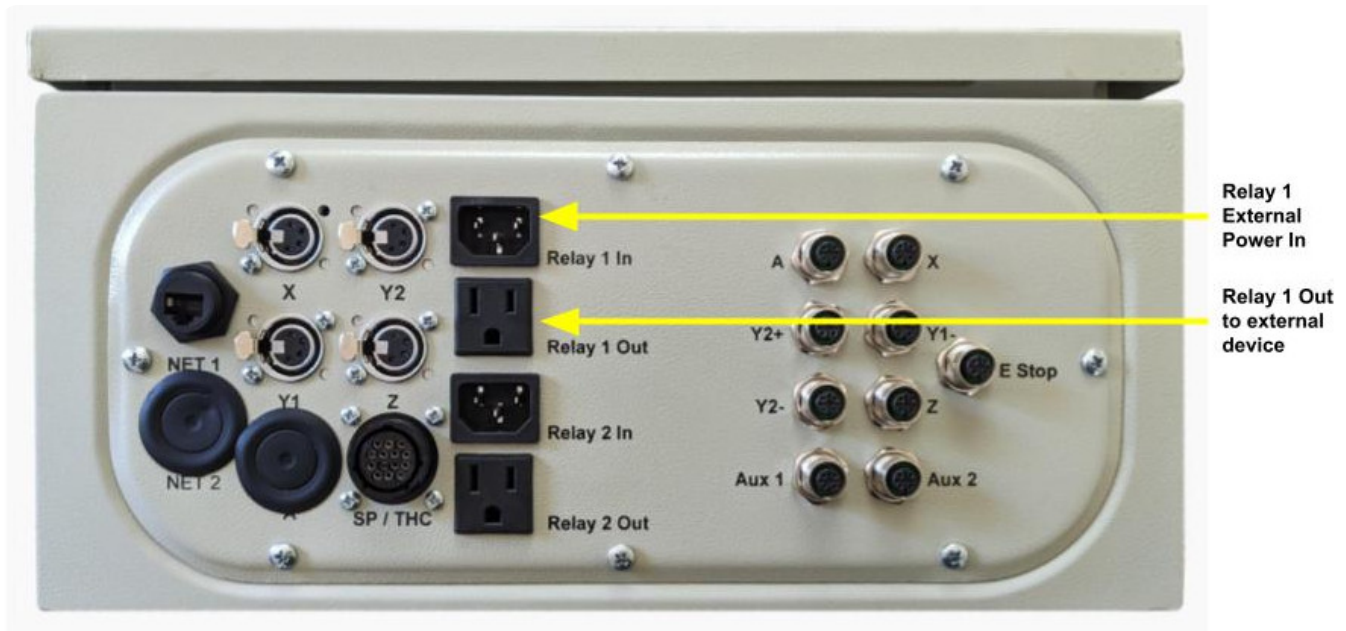

Relay 1 is rated for 250VAC and 15A[†] AC. The relay requires external AC power to be plugged in to "Relay 1 In" on the CNC controller. This output is commonly used in two ways:

- **Control a router:** When Avid CNC's version of **Mach4** is configured with a router cutting tool, the router should be plugged into "Relay 1 Out". By default it is controlled by either the **Router toggle button** in Mach4 or by G-code with M03 (spindle ON) and M05 (spindle OFF) commands.
- **Control a dust collector, coolant system, or general AC load:** When Avid CNC's version of **Mach4** is configured with a spindle or plasma cutting tool, relay 1 can be controlled either manually or using G-code. To manually operate the relay, use the **relay 1 toggle button**. Using G-code, M08 will turn relay 1 on and M09 will turn BOTH relay 1 and relay 2 off.

[†] The C13 type relay power plugs/sockets are rated for 15A in North America and 10A in most international regions.

Relay 2 Output Connections

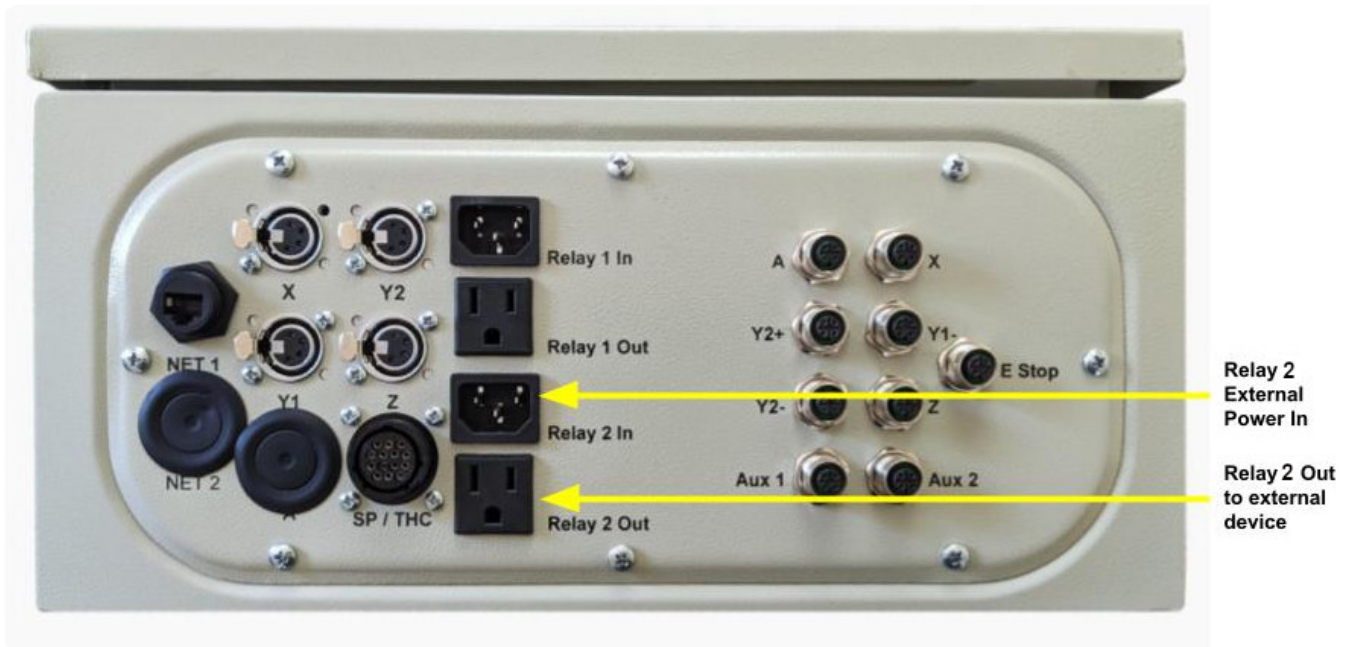

Relay 2 is rated for 250VAC and 15A[†] AC. The relay requires external AC power to be plugged in to "Relay 2 In" on the CNC controller.

This output is commonly used for dust collection or coolant systems, but can be used for many general AC loads. Relay 2 can be controlled manually in Mach4 with the **relay 2 toggle button**. The use of G-code to operate relay 2 will depend on your **Mach4 configuration**.

- Router cutting tool: Use M08 to turn relay 2 on and M09 to turn relay 2 off.
- Spindle or plasma cutting tool: Use M07 to turn relay 2 on and M09 to turn BOTH relay 1 and relay 2 off.

[†] The C13 type relay power plugs/sockets are rated for 15A in North America and 10A in most international regions.

3rd Party Spindle/VFD or non-Hypertherm Plasma Torch Connections

Use the information below to adapt external equipment to the 14-pin control cable supplied with the Avid CNC Plug and Play controller. The 14-pin female connector is pre-wired into the Plug and Play controller with these functions. Note: "Plasma" wires are only connected in plasma-enabled Plug and Play systems.

14-Pin Control Cable Pinout

Application

Plasma pins are populated but not connected by default on routing controllers, and Spindle pins are populated but not connected on plasma controllers.

ConnectorPin #	Use	In / Out	Description	Color	ESS Port/Pin
1	Spindle	Digital In	Fault Ground	Blue	
2	Spindle	Digital In	Fault Signal	White	2/13
3	Plasma	Digital Out	Torch ON	Orange/Black	3/17
4	Plasma	Digital Out	Torch ON	Green/Black	
5	Plasma	Analog In	Voltage Divider -	Red/Black	
6	Plasma	Analog In	Voltage Divider +	Red/White	
7	Spindle	Digital Out	FWD	Orange	2/14
8	Spindle	Digital Out	DCM	Green	
9	Spindle	Analog Out	AVI	Red	2/1
10	Spindle	Analog Out	ACM	Black	
11	Spindle	(optional) Analog	10V Ref	Blue/White	
12	Plasma	Digital In	Arc OK	White/Black	3/10
13	Plasma	GND	Ground	Blue/Black	
14	Plasma	Signal GND	Arc OK Ground	Green/White	

Pin 1/2, Fault Signal/Fault Ground: This input is used to read a fault from an external VFD, typically from thermal overload or a disconnected spindle power cable.

Pin 3/4, Torch ON: This output is from a small dry contact relay on the TMC3in1 used to trigger a CNC controllable plasma torch ON/OFF.

Pin 5/6, Voltage Divider: This input is the Tip Voltage used for Torch Height Control (THC). It is critical that the (+)(-) polarity of this signal is correct, as well as the voltage divider ratio. The ratio must be 50:1 (used by Hypertherm and preset in the Avid CNC Mach4 profile), 40:1, 30:1, 20:1, 16.67:1, or 15:1. **Note:** Do not connect raw tip voltage, this will damage the TMC3in1.

Pin 7/8, Spindle Relay: This output is from a small dry contact relay on the CRP850 breakout board and is used for sending an on/off signal to an external VFD, typically for a forward/stop command.

Pin 8/9, Spindle Analog Signal: This output is a 0-10V analog signal used to control VFD frequency/spindle RPM.

Pin 11, 10V Reference: Unused in most systems, this pin can provide a 10V reference if required by the VFD.

Pin 12/14, Arc Okay: This input signals to the CNC controller that the plasma arc has successfully transferred to the material and the cut program can continue motion. Typically the plasma power supply will close a dry contact relay to control this signal.

Custom M12 Inputs Connections

For custom machine applications, the M12 sensor inputs on the CRP860-00E breakout board can be used for purposes other than limits and probes. The inputs are Normally Open, rated for 12V, and follow a standard M12 A-coded pinout. See the section for more details on pin assignments in Mach4.

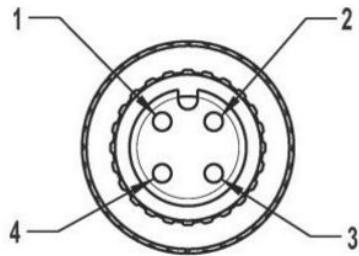

+12V
N.C.
GND
N.O.

- Sensor Cables are A-Coded M12 connector standard.
- Pin 1 (Brown wire) is Power (12V or 24V)
- Pin 2 (White wire) is Normally Closed signal
- Pin 3 (Blue wire) is Ground
- Pin 4 (Black wire) is Normally Open signal

This picture is looking at a Female connector body - pin assignments will be mirrored for Male.

Note

Not all pins are populated for connectors on the CRP860-00E IO breakout board.

- **Sensor and Aux inputs:** Pin 2 (Normally Closed) is not populated
- **E Stop input:** Pin 4 (Normally Open) is not populated

System Settings

DIP switch Settings

DIP switch settings on the motor drives will vary depending on your application. The DIP switch positions are shown below.

CRP8070 for 7.0A 1/2" NEMA 34 motors

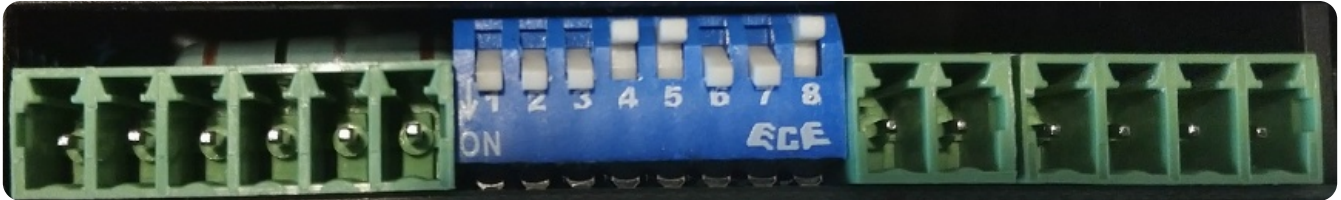

CRP5056 for 4.2A 3/8" Nema 23 motors

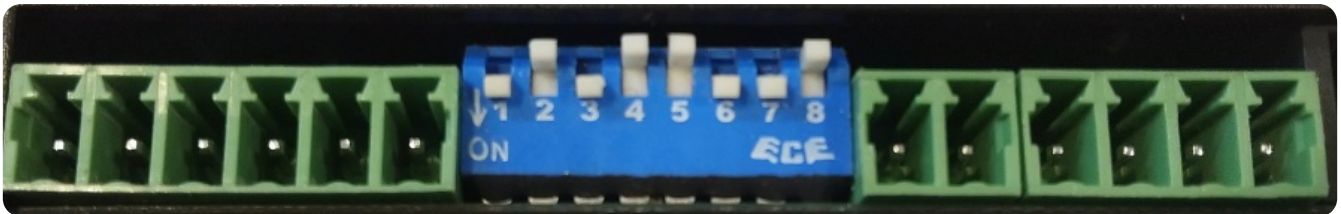

If you are using an Avid CNC rotary axis on a NEMA 23 system, be sure the rotary axis motor is hooked up to the 5th drive with that drive's DIP switch positions are set as shown below.

CRP5056 for 5.0A motors

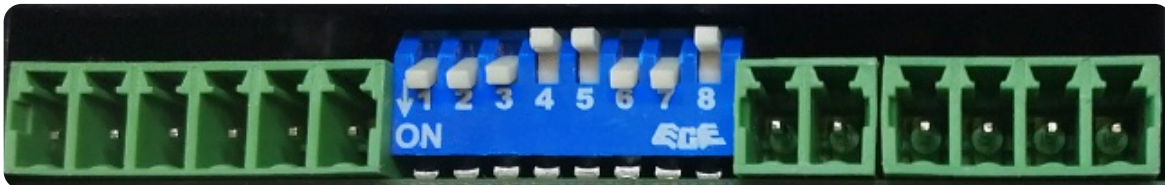

ESS Jumper Settings

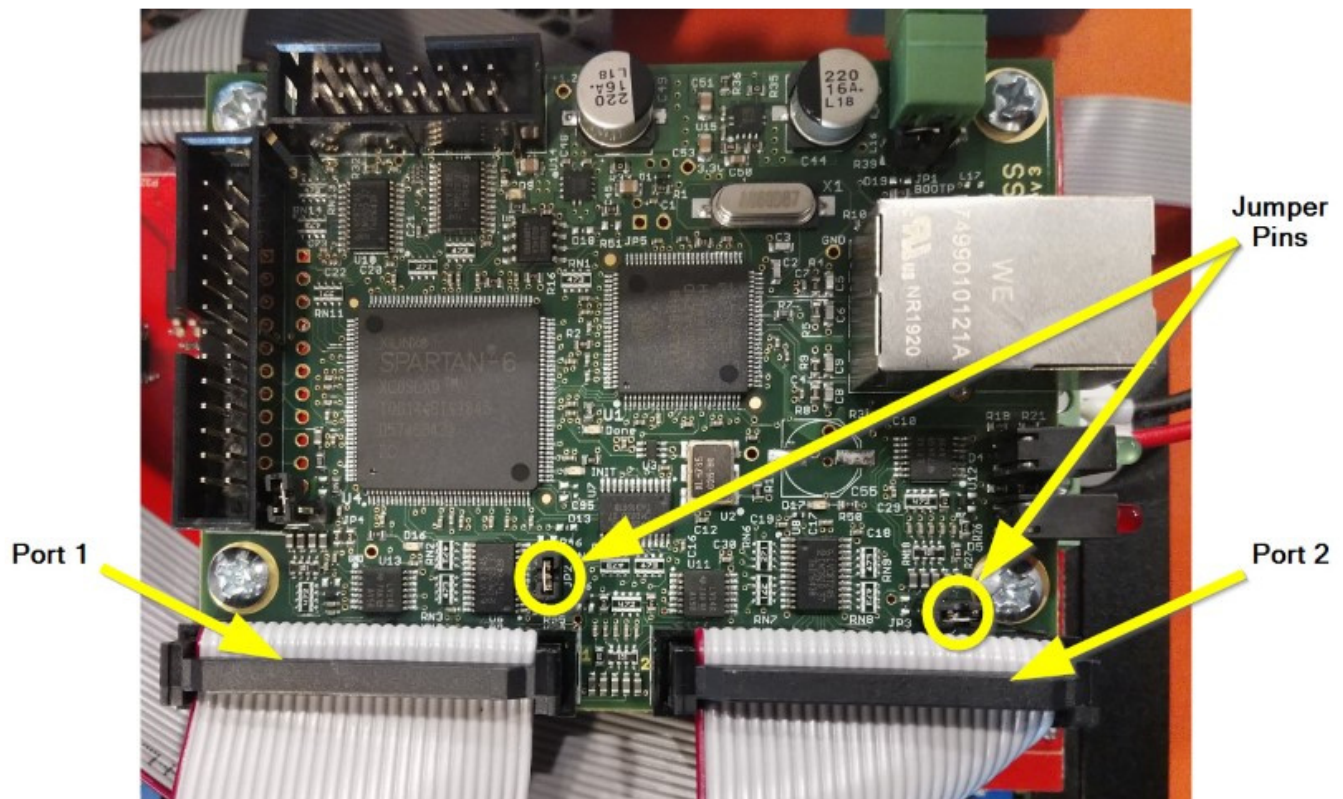

The jumper pins shown here can provide 5V to pin 26 of their adjacent header, port 1 or port 2. The ESS comes pre-configured in the CNC controller with these jumpers connected on port 1 and port 2.

Peripherals

Adding Additional IO (non-Plasma Systems)

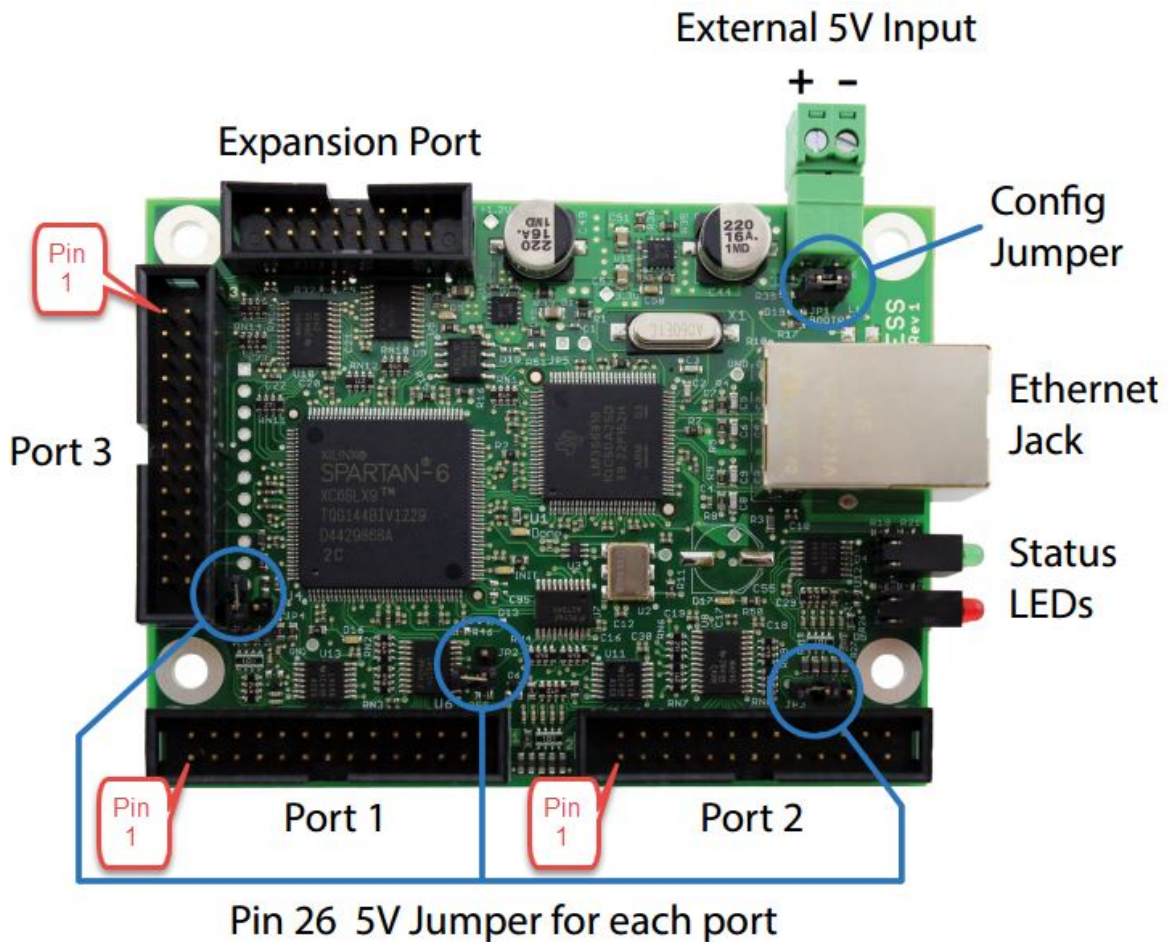

If the existing IO (both the M12 sensor inputs and the screw terminals on the CRP850-00E-F01 Breakout Board) are not enough for your application, it is possible to add an additional ribbon cable and breakout board to the Ethernet Smoothstepper (ESS). Port 3 on the ESS is a standard 26-pin low profile male parallel port connector. Connecting this to an external breakout board will expose 4 outputs, 8 inputs, and 5 bi-directional pins. You will need at minimum:

- A ribbon cable with appropriate connectors. To power the breakout board from the ESS a 26-pin connector on both ends is required.
- A breakout board with appropriate connectors and opto-isolation for the input signals.

For complete information see Warp9's documentation: warp9td.com/index.php/documentation/doc-ess

Schematics

CRP850-00E Breakout Board

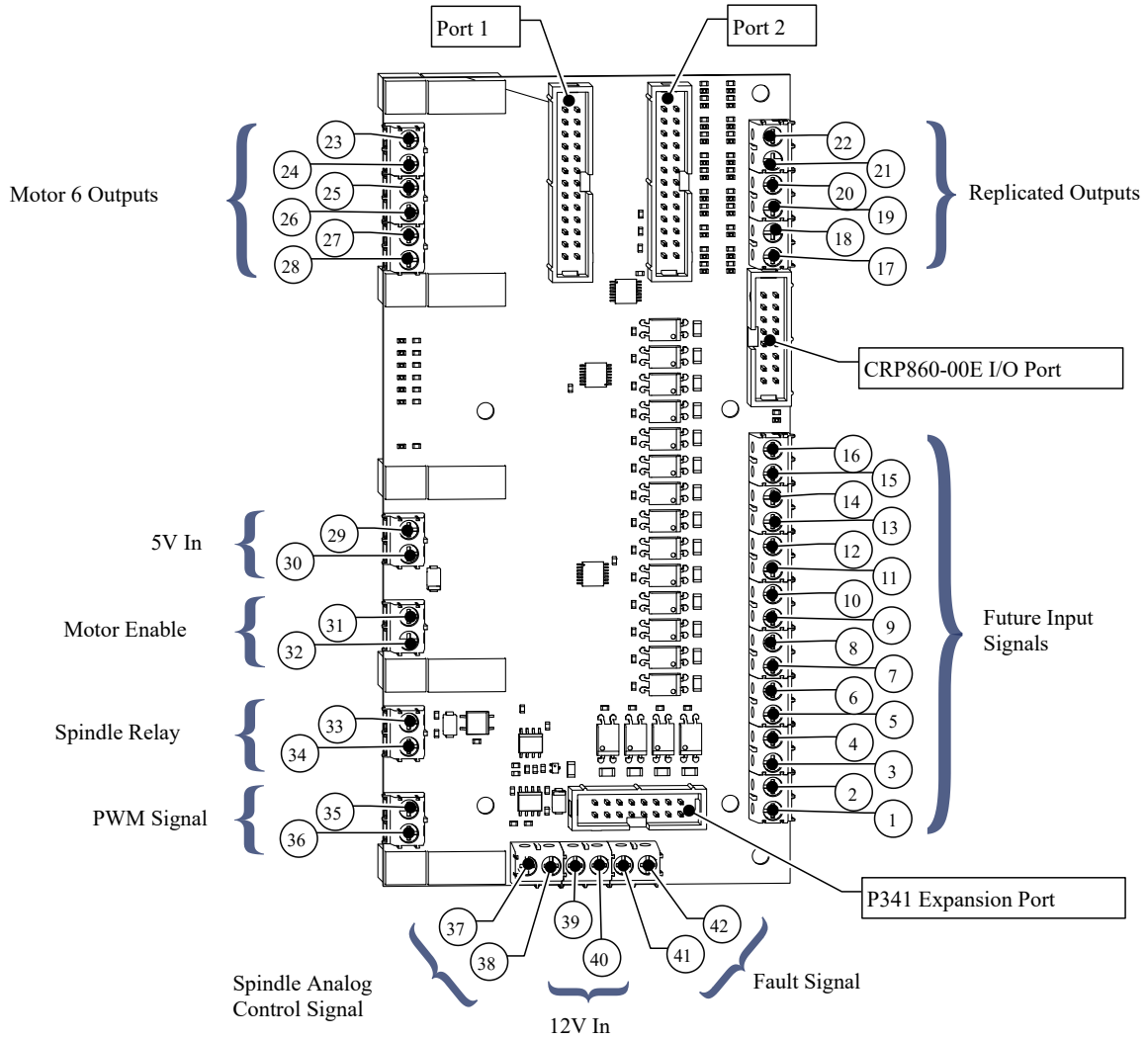

Listed on the following pages are descriptions and port/pin assignments.

Future Signal Inputs: The signal inputs on the CRP850-00E board are designed for NPN signals, which close signal to ground. The input signal terminals provide ports for direct wiring of limit switches, touch plate, and auxiliary signals.

Replicated Outputs: These are 5V digital outputs which can be used to drive relays with 5V coils or 5V logic level devices. They are replicates of the spindle relay and two output relays (Relay #1 and Relay #2). Note, these outputs are not relays themselves. The same signals (for Relay #1 and Relay #2) are replicated through the CRP860-00E I/O port, which goes out to the CRP860-00E board and are normally tied to solid state relays used for controlling AC loads.

Motor 6 Outputs: These outputs can be used with an additional motor driver to control a sixth motor.

5V IN: The CRP850-00E board can be powered either by 5V through this port, or via pin 26 on port 1. In most CRP800 applications, this port is not used, as 5V is passed through to the CRP850-00E board on pin 26 from the Ethernet Smoothstepper.

Motor Enable: When this terminal is jumpered, the CRP850-00E board will place a 5V potential across the motor enable terminals on all 5 motor driver connectors, disabling the motors. Typically, a mechanical switch is connected to these terminals. When the switch is closed, the motors are disabled so that the machine can be manually positioned, and motors can be safely plugged and unplugged from the system without powering down the entire controller.

Spindle Relay: These terminals provide contacts for a small dry contact relay useful for sending an on/off signal to an external VFD, typically for a forward/stop command. This signal is wired into pins 7 and 8 on the SP/THC connector in CRP800 controllers.

PWM Signal: These terminals provide a digital 0-5 signal designed to be used for speed control via PWM. This same signal (output 1 on port 2) is also routed through analog circuitry on the board to produce a 0-10V analog output.

Spindle Analog Control Signal: These terminals provide a 0-10V analog output typically used for speed control on an external VFD. This signal is wired to pins 9 and 10 on the SP/THC connector in CRP800 controllers.

12V IN: The CRP850-00E requires 12V power, both to power the optical isolators connected to all input signals, and to provide a voltage that is regulated to 0-10V for the Spindle Analog Control Signal.

Fault Signal: This input signal terminal is specifically designed to read a fault from an external VFD, typically from thermal overload or a disconnected spindle power cable.

Phoenix Connector Terminal Blocks

Note: these Port and Pin assignments match the ESS configuration

Terminal #	Description	Port/Pin	Voltage
1	Signal Input (FF8)	2/12	12V
2	GND		12V
3	Signal Input (FF7)	2/11	12V
4	GND		12V
5	Signal Input (FF6)	2/10	12V
6	GND		12V
7	Signal Input (FF5)	1/15	12V
8	GND		12V
9	Signal Input (FF4)	1/13	12V
10	GND		12V
11	Signal Input (FF3)	1/12	12V
12	GND		12V
13	Signal Input (FF2)	1/11	12V
14	GND		12V
15	Signal Input (FF1)	1/10	12V
16	GND		12V
17	Relay 1 Output (OUT1)	2/17	5V
18	GND		5V
19	Relay 2 Output (OUT2)	2/16	5V
20	GND		5V
21	Spindle Relay Output (OUT3)	2/14	5V
22	GND		5V
23	Motor 6 Step	1/1	5V
24	GND		5V
25	Motor 6 Dir	1/17	5V
26	GND		5V
27	Motor Enable		5V
28	GND		5V
29	5V In		5V
30	GND		5V
31	Motor Enable		5V
32	GND		5V
33	Spindle Relay FWD	2/14	
34	Spindle Relay DCM		
35	PWM		0-5V
36	GND		5V
37	Spindle 0-10V	2/1	0-10V



38	Spindle ACM		10V
39	12V In		12V
40	GND		12V
41	Spindle Fault Input	2/13	12V
42	GND		12V



CRP860-00E I/O Port Pin Assignments

Note: these assignments are **not** used in the ESS configuration

Pin #	Description
1	+12V
2	X Sensor Signal
3	Y1- Sensor Signal
4	Y2- Sensor Signal
5	Touch Sensor Signal
6	A Sensor Signal
7	Y2+ Sensor Signal
8	Z+ Sensor Signal
9	AUX 2 Signal
10	E-Stop Signal
11	+5V
12	Relay 1 Control Switch
13	Relay 2 Control Switch
14	GND I/O
15	12V GND
16	12V GND

CRP850-00E Diagnostic LEDs

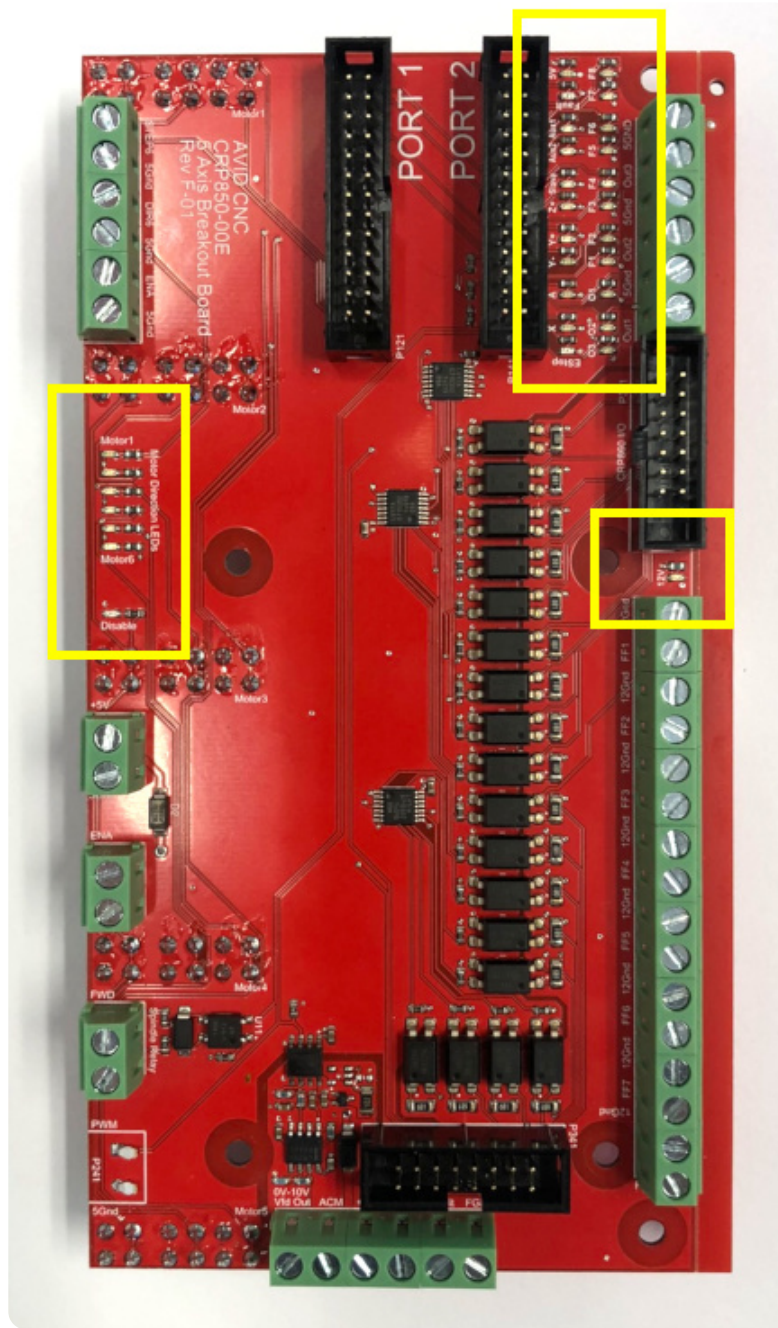

Diagnostic LEDs are located in three places on the CRP850-00E breakout board. These provide a quick way to troubleshoot whether and input or output is being activated.

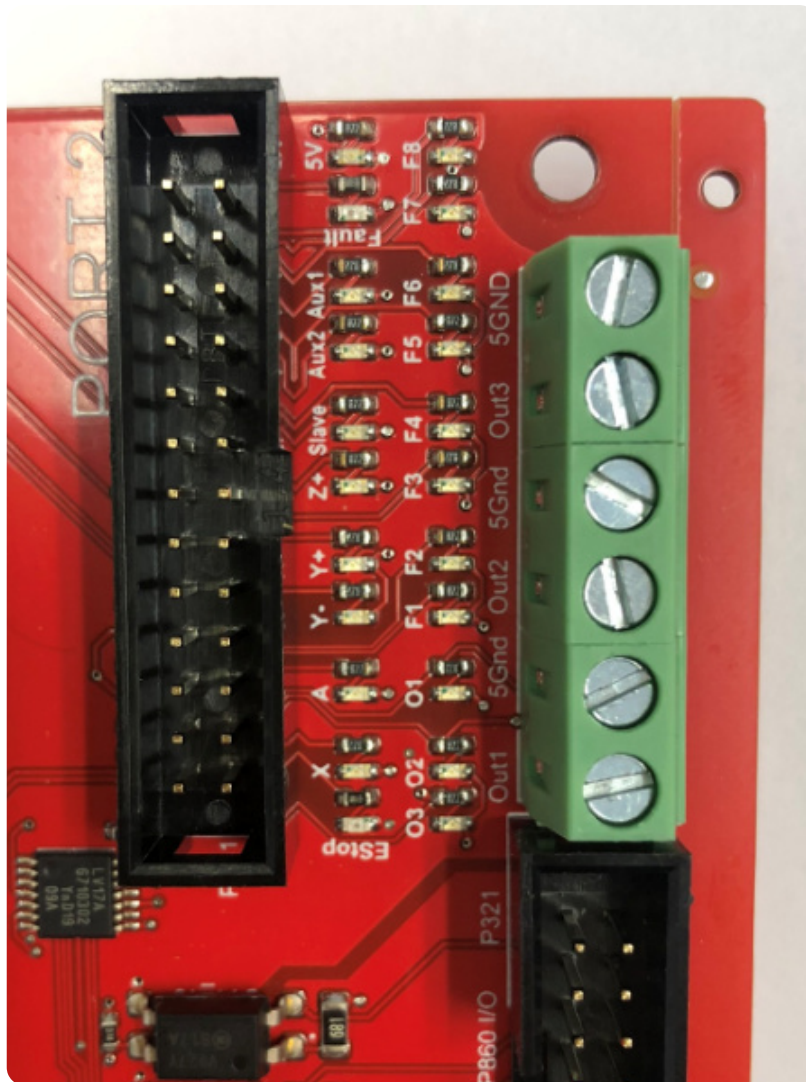

Diagnostic LEDs:

- Sensor input signals
- Future input signals (FF1 - FF8)
- EStop
- 5V In
- Relay #1 output signal
- Relay #2 output signal
- Spindle relay output signal

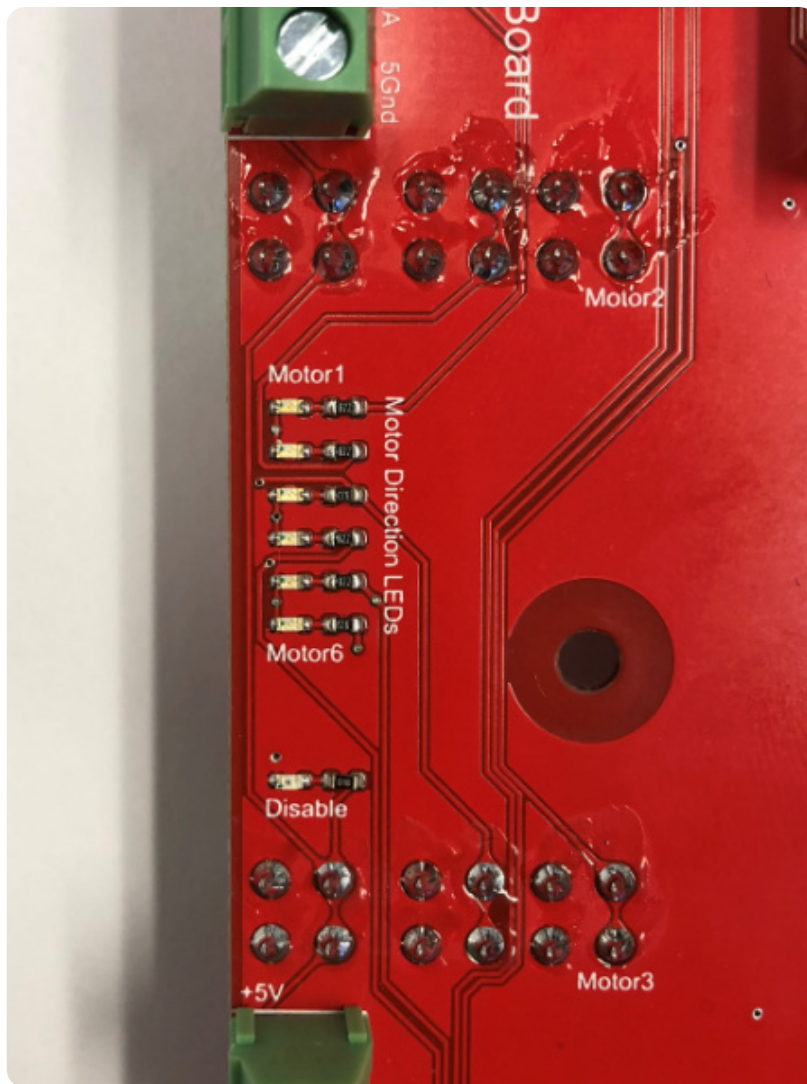

Diagnostic LEDs:

- Motor 1 - 6 direction
- Motor enable / disable



Diagnostic LEDs:

- 12V In

CRP860-00E Break-out-Board

FRONT VIEW

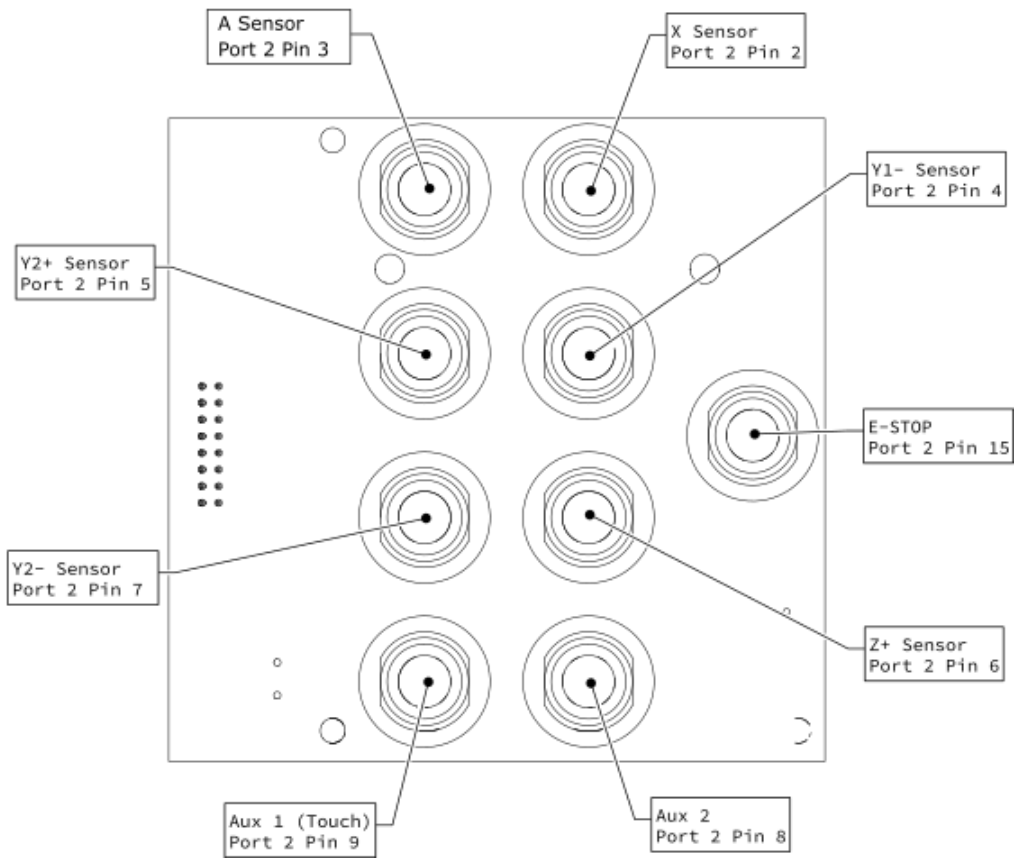

Note

All M12 inputs are A-coded. See [M12 Sensor Inputs](#)

BACK VIEW

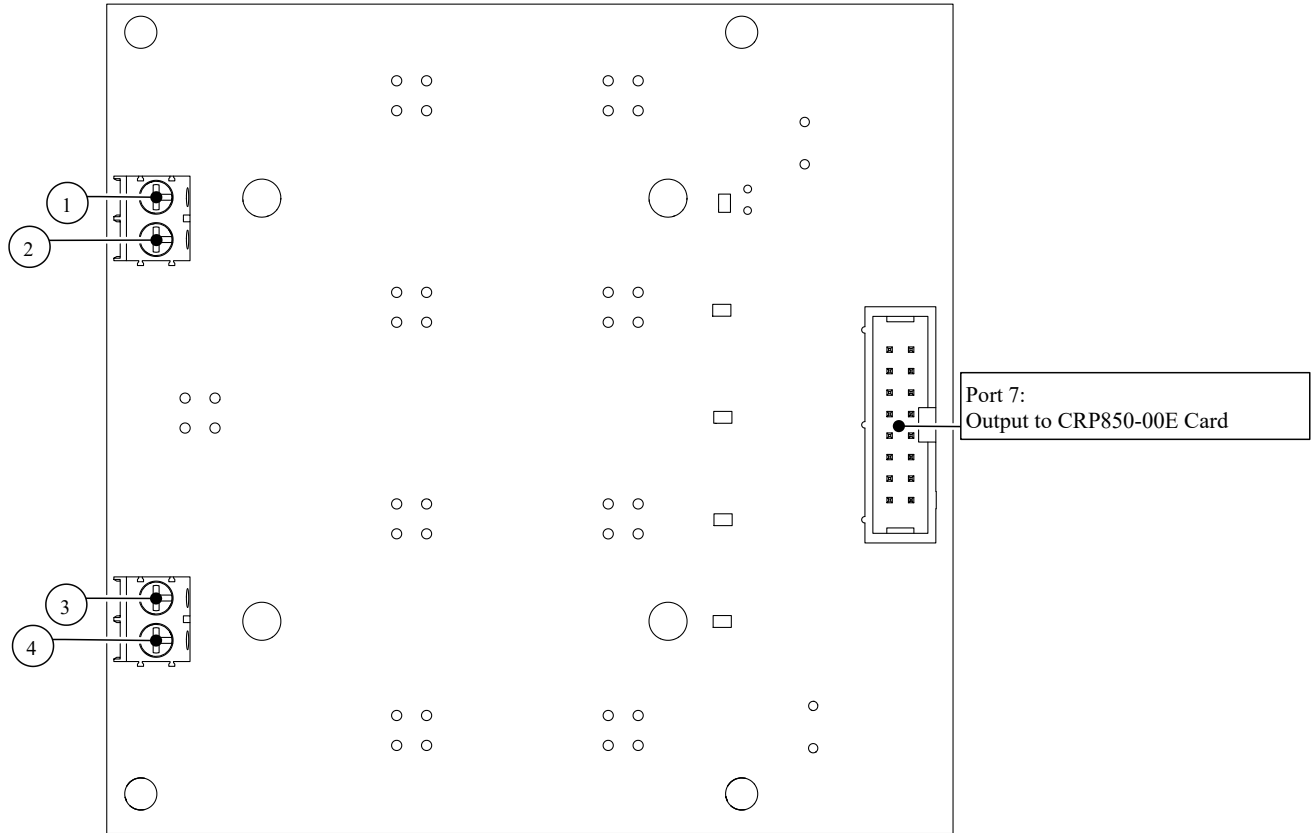

Phoenix Connector Terminal Blocks

Note: these Port and Pin assignments match the ESS configuration

Terminal #	Description	Pin (Port 2 on CRP850-00E card)
1	Relay 1 Control Switch	17
2	5V GND	
3	Relay 2 Control Switch	16
4	5V GND	

Common Connector Pinouts

M12 Sensor Inputs

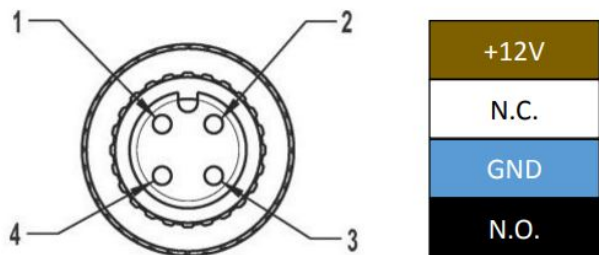

- Sensor Cables are A-Coded M12 connector standard.
- Pin 1 (Brown wire) is Power (12V or 24V)
- Pin 2 (White wire) is Normally Closed signal
- Pin 3 (Blue wire) is Ground
- Pin 4 (Black wire) is Normally Open signal

This picture is looking at a Female connector body - pin assignments will be mirrored for Male.

Note

Not all pins are populated for connectors on the CRP860-00E IO breakout board.

- **Sensor and Aux inputs:** Pin 2 (Normally Closed) is not populated
- **E Stop input:** Pin 4 (Normally Open) is not populated

14-pin Control Cable

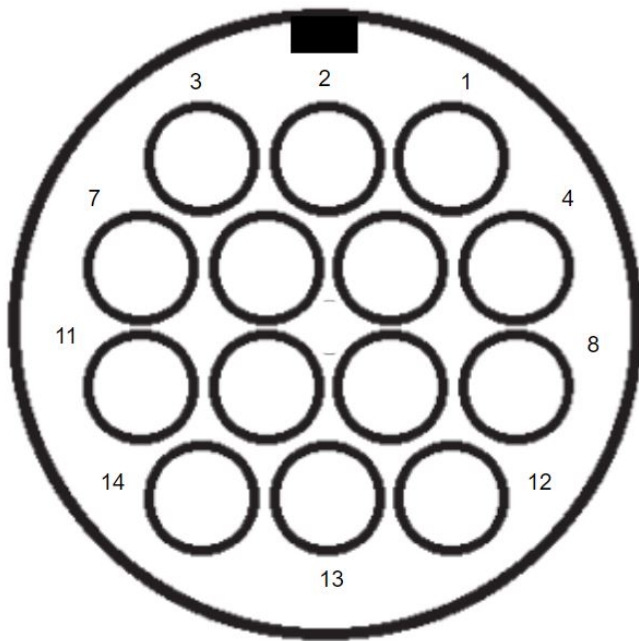

FEMALE connector

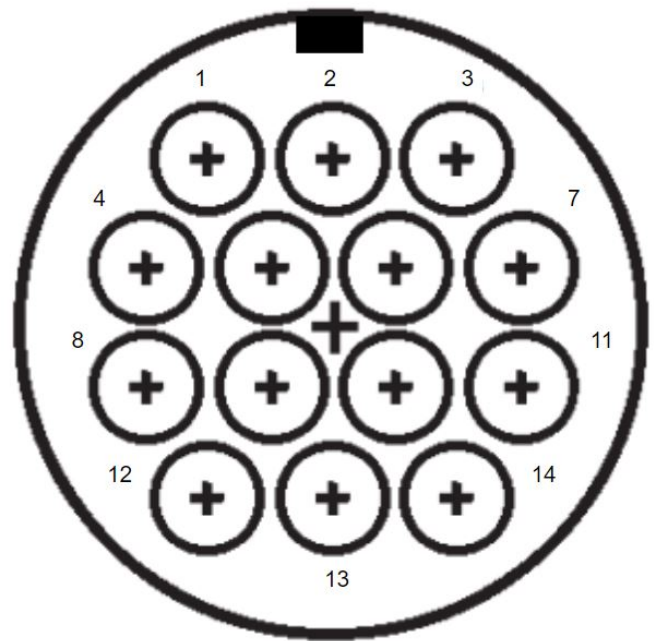

MALE connector

i Application

Plasma pins are populated but not connected by default on routing controllers, and Spindle pins are populated but not connected on plasma controllers.

ConnectorPin #	Use	In / Out	Description	Color	ESS Port/Pin
1	Spindle	Digital In	Fault Ground	Blue	
2	Spindle	Digital In	Fault Signal	White	2/13
3	Plasma	Digital Out	Torch ON	Orange/Black	3/17
4	Plasma	Digital Out	Torch ON	Green/Black	
5	Plasma	Analog In	Voltage Divider -	Red/Black	
6	Plasma	Analog In	Voltage Divider +	Red/White	
7	Spindle	Digital Out	FWD	Orange	2/14
8	Spindle	Digital Out	DCM	Green	
9	Spindle	Analog Out	AVI	Red	2/1
10	Spindle	Analog Out	ACM	Black	
11	Spindle	(optional) Analog	10V Ref	Blue/White	
12	Plasma	Digital In	Arc OK	White/Black	3/10
13	Plasma	GND	Ground	Blue/Black	
14	Plasma	Signal GND	Arc OK Ground	Green/White	

DB9 Motor Connectors

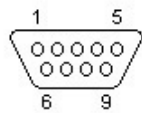

DB-9 Male

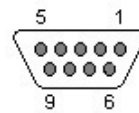

DB-9 Female

Pin #	Function	Wire Color
1	Current Set Resistor	N/A
2	N/C	N/A
3	N/C	N/A
4	N/C	N/A
5	Current Set Resistor	N/A
6	B + Phase	Yellow
7	B - Phase	Blue
8	A + Phase	Red
9	A - Phase	Green

XLR Motor Connectors

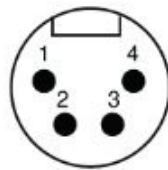

(male connector)

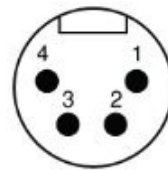

(female connector)

Pin #	Motor Phase	Wire Color
1	A +	Red
2	A -	Green
3	B +	Yellow
4	B -	Blue

Wiring Diagrams

Application

Wiring diagrams shown below are for 4-axis (5 motor drivers) systems.

NEMA 23

NEMA 23 - 21.2 Revision

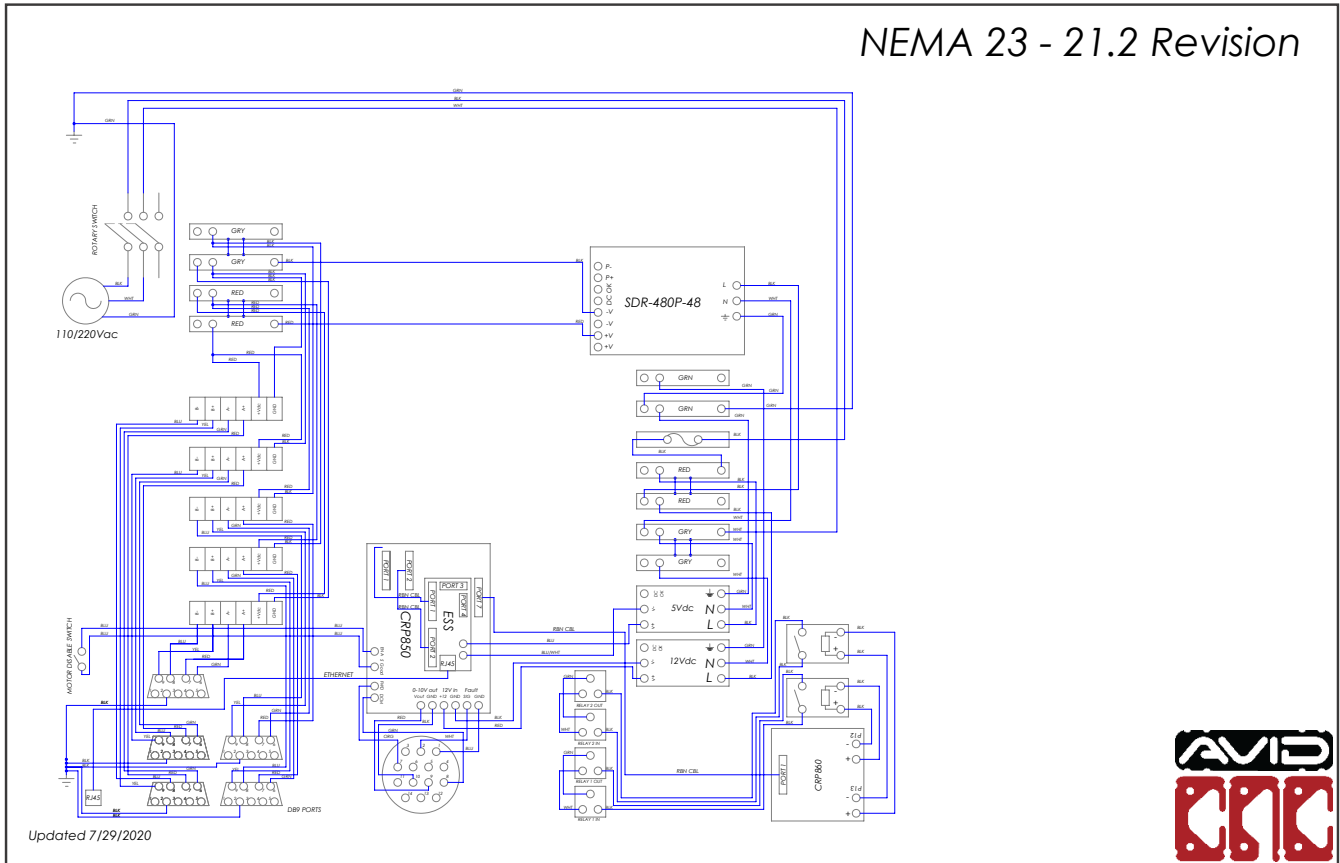

NEMA 23 Plasma

NEMA 23 Plasma - 21.2 Revision

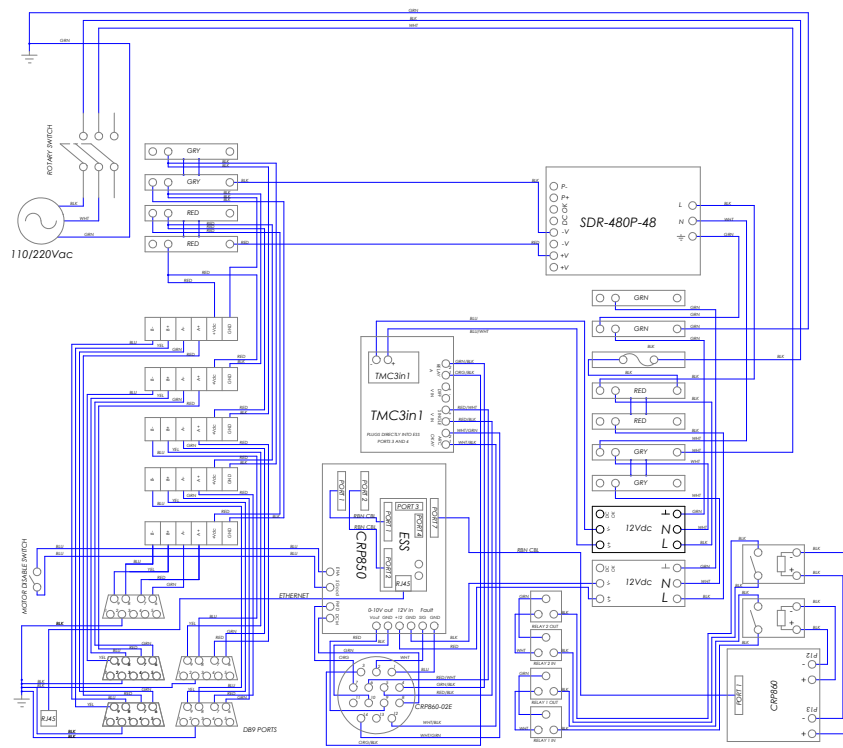

Updated 3/9/2022



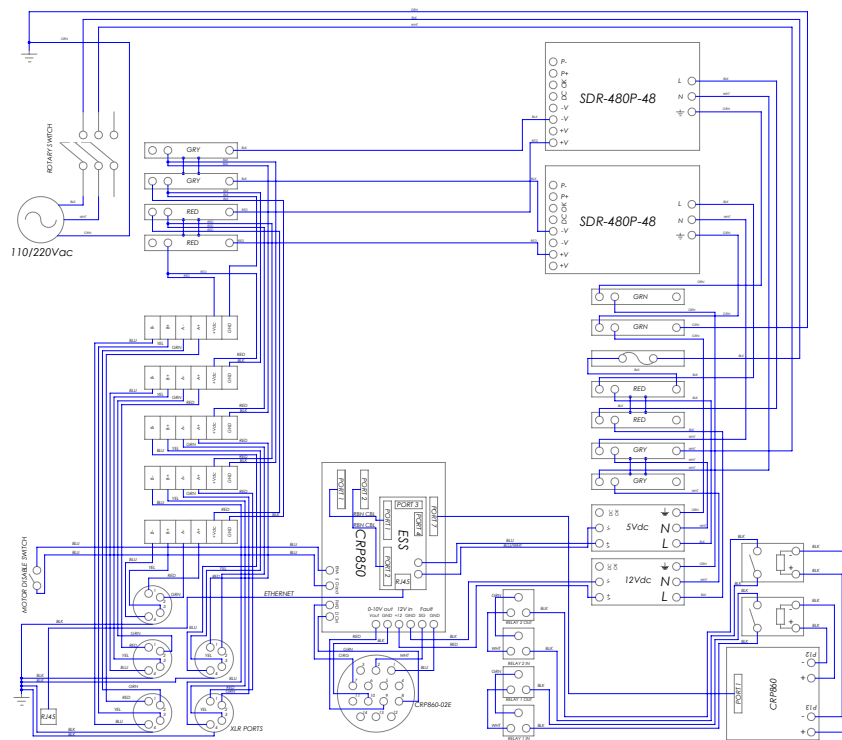

Updated 7/29/2020



NEMA 34 Plasma

NEMA 34 Plasma - 21.2 Revision

